

U.S.SAWS™

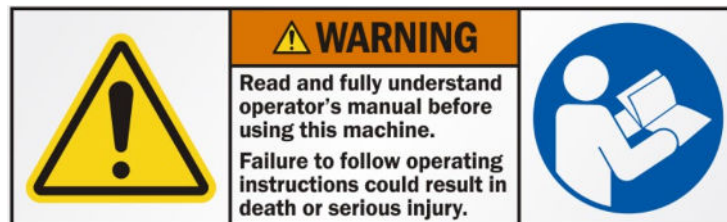

U.S.SAWS JS - 160 OPERATING MANUAL



Notice of Copyright Protection

Copyright 2020, by U.S.SAWS . All rights reserved. This work may not be reproduced or disseminated in whole or in part by any means without the prior written permission of U.S.SAWS

10-24-2024

U.S.SAWS™

**SURFACE PREP
DIVISION**

P: 877-817- 6687 F: 813-621-7125
Visit us at www.ussaws.com
sales@ussaws.com



INTRODUCTION & SPECIFICATIONS

1.0 INSTRUCTIONS FOR USE OF MANUAL SECTIONS

Section	Page
Table of Contents & Introduction	2
Symbols & Decals	3
Safety Instruction	4 - 5
Pre-Operation Checklist	6 - 8
Operation	9 - 10
Parts Breakdown	11 - 13
Maintenance & Inspection	14 - 15
Propane Power System	16 - 46
Warranty & Service	47 - 48

Foreword/Introduction

The owner's manual is intended to point out some of the basic safety situations that maybe encountered during the normal operation & maintenance of the JS Walk Behind Machine & to instruct you in safety practices for dealing with these conditions. Keep all manuals provided with your machine in a safe place at all times.

The information and specifications included in this publication were in effect at the time of approval for printing. U.S.SAWS reserves the right, however, to discontinue or change specifications or design at any time without notice and without incurring any obligation.

Typical applications for the U.S.SAWS JS SERIES SAWS would be joint cleanout and trench cutting. The saw uses dry cut diamond blades in either 8" diameters or 10" diameters with an allowable maximum depth cut of 3". The blade rotates in an upward direction allowing for easy dust collection when connected to an appropriate vacuum system. The machine should always be operated with a dust collection system and in a well-ventilated area due to carbon monoxide fumes emitted from the gasoline engine.

Features:

- Certified propane power - the 479cc Briggs and Stratton Vanguard V-Twin is a certified propane engine. It features electric start and the twin-cylinder design has reduced vibration
- Equipped with a CO-2 monitor
- Upcut blade rotation removes debris and material from the joint and ejects it up towards the vacuum port
- Versatile blade configurations provide solutions for joint clean-out and spalled joint restoration
- New and improved polyurethane blade guard seals help contain dust
- Redesigned belt drive system for easier maintenance and longer wear life
- Front and rear pointer guides for accuracy
- Screw jack depth adjustment and "quick lift" blade retraction handle for consistency and safety

Read this entire operations and maintenance manual before using your new tool. Pay close attention to the Rules for safer operation,

Dangers, Warnings and Cautions.

The purpose of safety symbols and explanations are to attract your attention to possible hazards and how to avoid them. The safety symbols and explanations do not by themselves eliminate any danger. The instructions or warnings they give are not substitutes for proper accident prevention measures.



DANGER: Indicates an imminently hazardous situation that if not avoided, will result in death or serious injury. This signal word is limited to the most extreme situations.



WARNING: Indicates a potentially hazardous situation that, if not avoided, could result in death or serious injury.



CAUTION: Indicates a potentially hazardous situation that, if not avoided may result in minor or moderate injury. It may also be used to alert against unsafe practices that may cause property damage.

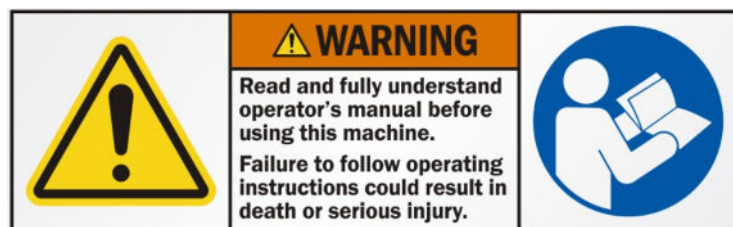

2.0 SPECIFICATIONS

Model	JS-160 - Propane
Part Number	SX77160
Fuel Type	Propane
Fuel Capacity	14 lbs / 3-4 hour run time
Engine Size/ Brand	V-Twin 479CC, 16 HP Vanguard
Max RPM	5,850
Max Cutting Depth	3"
Blade Sizes	8" to 10" Dry Diamond
Max Width	Single Blade: .500" Multiple Blades: 1.5"
Minimum Blade Width	.095"
Blade Width	.095", .110", .125", .187", .250", .375", .500"
Arbor Size	1" with Drive Pin Hole
Dust Collector Size	350+ CFM
Weight	250 lb



SYMBOLS & DECALS

3.0 SYMBOLS & DECALS

For Safe Operation

You must be qualified for safe operation of the U.S.SAWS JS walk behind machine. You must clearly understand the written instructions supplied by U.S.SAWS, be trained - including actual operation - & know the safety rules & regulations for the job site. It is a safety practice to point out & explain safety signs & practices to others & to make sure they understand the importance of following these instructions.

Be Safe

Human error is the result of many factors: carelessness, fatigue, sensory overload, preoccupation, unfamiliarity with the machine or attachments, or drugs or alcohol, to name a few. You can avoid serious injury or death caused by these & other unsafe work practices. Be safe and never assume accidents cannot happen to you.

For your safety and the safety of others, act safely and encourage your fellow workers to act safely as well.



Read and understand operator's manual before using this machine. Failure to follow operating Instructions could result in injury or damage to equipment.



Use only diamond blades (steel centered diamond cutting-off wheels) with this machine. RPM rating on blade must exceed machine max rpm rating. The use of any other blade could result in death or serious injury.

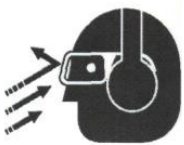

Flying debris and loud noise hazards. Wear ear and eye protection



Engine exhaust contains poisonous carbon monoxide gas. Breathing it could cause death. Operate machine in well ventilated area.



AVOID INJURY.

Do NOT operate with guard removed. Replace guard before operating machine.



Wear safety boots when operating this machine



Wear appropriate clothing



Wear Head Protection, breathing protection, and the use of hearing protection is mandatory



Wear hand protection



Wear proper electrostatic grounding equipment at all times. Static discharge during fueling can cause explosion



Keep all guards in place



Rotating blade hazard. Do NOT operate with guard up. Keep hands and feet away.



TO AVOID INJURY.

Always inspect saw blades before use. Replace all cracked or damaged blades.



SAFETY INSTRUCTIONS

4.0 SAFETY INSTRUCTIONS

4.1 KNOW THE RULES & YOUR EQUIPMENT.

Most job sites have rules governing equipment use & maintenance. Before starting at a new work location, check with the supervisor or safety coordinator. Ask about any rules or regulations you need to abide.

OSHA enforces federal laws within the United States that apply to the safe operation, application, & maintenance of equipment on job sites. It is the employer's responsibility to comply with these laws.

Do not operate this machine unless you have read the operations and maintenance manual carefully. Read any additional instructions included from other manufacturers and organizations such as the Masonry and Concrete Saw Manufacturers Institute. Learn the applications and limitations as well as the specific potential hazards related to this tool

4.2 RECEIVE PROPER TRAINING.

Do not operate this machine unless you have received operational and maintenance training from a U.S. SAWS representative or from an authorized distributor for U.S.SAWS.

4.3 PROTECT YOUR FEET.

Observe all applicable local, state and federal safety regulations. Wear OSHA approved foot protection.

4.4 PROTECT YOUR EYES.

Observe all applicable local, state and federal safety regulations. Wear OSHA approved safety glasses.

4.5 PROTECT YOUR LUNGS.

Breathable silica may be generated by use of this product. Silica can cause severe and permanent lung damage, cancer, and other serious diseases. Do not breathe the dust. Do not rely on your sight or smell to determine if the dust is in the air. Silica may be in the air without a visible dust cloud. If air monitoring equipment for silica is not provided by your employer at your work site, you **MUST** wear appropriate respiratory protection when using or servicing the machine. Consult your employer and OSHA regarding the appropriate respiratory protection.

4.6 PROTECT YOUR HEARING.

Observe all applicable local, state and federal safety regulations. Wear OSHA approved hearing protection.

4.7 DRESS PROPERLY.

Do not wear loose clothing or jewelry that can be caught in moving parts. Wear protective hair covering to contain long hair. Keep hair away from motor air vent. Rubber gloves and non-skid footwear are recommended when working outdoors

4.8 AVOID A DANGEROUS ENVIRONMENT.

Do not expose machine to rain. Do not use machine in wet conditions. Keep work area well lit. When working at an elevated location, pay attention to articles and persons below.

4.9 BEWARE OF HIDDEN DANGERS IN CONCRETE.

Rebar or utility lines may be buried in concrete. Disconnect the power to any utility lines. If these items are to be missed, clearly mark the area. If these items are to be cut, check the blade manufacturer's guidelines on material to be cut.

4.10 AVOID ANY AREAS OR ACTIONS THAT EXPOSE YOU TO CARBON MONOXIDE.

Exhaust gas from gasoline engines contains dangerous carbon monoxide. Breathing it can cause unconsciousness and even kill you. Always operate gasoline engine machines in a well-ventilated area. Do not operate in areas where exhaust fumes could accumulate without wearing appropriate respiratory protection. Consult your employer and OSHA regarding use of appropriate respirator for dangerous carbon monoxide gases.

4.11 KEEP WORK AREA CLEAN. DO NOT RUN OVER ANYTHING.

Loose objects could be thrown from crack. Make sure area to be cut is clear from people and any loose objects, nuts, bolts, etc. Never run over any loose objects.

4.12 KEEP CHILDREN AND VISITORS AWAY.

Do not allow anyone to stand in line with the blade path. Do not let children or visitors contact machine or extension cord. Keep children and visitors away from the work area.

4.13 AVOID FLAMMABLE LIQUIDS OR GASES.

Engines and diamond blades produce heat and sparks during operation. Never use machines in dangerous sites containing flammable, combustible or explosive materials such as lacquer, paint, benzene, thinner, gasoline, gases, and adhesive agents.

4.14 AVOID CONTACT WITH HOT MUFFLER.

The muffler becomes hot during operation and remains hot after stopping the engine. Do not touch the muffler while it is hot. Let the engine cool before storing indoors. Do not place flammable objects close to the engine.

4.15 AVOID CONTACT WITH HOT BLADE AND BLADE GUARD.

The blade and blade guard become hot during operation and remain hot after stopping the engine. Do not touch the blade and blade guard without proper hand protection.

4.16 KEEP FIRM GRIP ON MACHINE.

During normal operation as instructed in Section 6.0, keep a firm hold on the handle grips and maintain control of the machine until the blade completely stops.

4.17 SHUT OFF ENGINE.

When not in use, before servicing and when changing accessories shut off engine. Release the lever switch and move the on/off switch to the OFF position. Move the fuel valve lever to the OFF position.

4.19 CHECK BLADE AND MACHINE ROTATION DIRECTION.

Never operate a blade in the wrong rotation direction. Check the machine rotation direction and blade direction when mounting a blade.

4.20 CHECK BLADE MAXIMUM ALLOWABLE SPEED.

Check the maximum operating speed of the machine and blade. Never use a blade rated less than the machine's maximum speed rating.

4.21 CHECK BLADE FOR CRACKS, DAMAGE, AND MISALIGNMENT.

Never use a cracked, damaged, or misaligned blade. After mounting blade, rotate by hand to check for proper alignment.

4.22 CHECK DIAMOND BLADE FOR WARNINGS.

Many diamond blades contain a chemical known to the state of California to cause cancer and/or birth defects or other reproductive harm. Diamond blades improperly used are dangerous. Comply with American National Standards Institute Safety Code B71 and Occupational Safety & Health Act covering SPEED, SAFETY GUARDS, FLANGES, MOUNTING PROCEDURES, GENERAL OPERATING RULES, HANDLING, STORAGE & INSPECTION AND GENERAL MACHINE CONDITIONS. Read Diamond Blades Safety Manual before use.

4.23 DO NOT FORCE WRONG SIZE OR TYPE BLADE ONTO MACHINE.

Do not force a blade onto the machine shaft or alter the size of the arbor-mounting hole. Be certain that the drive pin is in place through the blade when tightening the blade nut. Never add a drive pin hole or modify a blade.

4.24 USE CORRECT SAW AND ACCESSORIES.

Do not force a small saw to do the job of a heavy-duty saw. Do not use the saw for improper applications. Never cut material for which the blade was not designed. Check blade manufacturer's guidelines on material to be cut.



SAFETY INSTRUCTIONS

4.25 STORE IDLE EQUIPMENT.

The machine, blades and tools should be stored in a dry and secure location when not in use. Keep equipment out of reach of children.

4.26 DO NOT FORCE SAW.

The saw will do the job better and safer at the rate for which it was designed.

4.27 OBTAIN SAFETY DATA SHEET (SDS) FOR ALL WORK SURFACE MATERIALS.

This includes primers, all coatings, adhesives, tile and crack filling materials, etc. Do not attempt to cut, clean out or remove material without SDS information. Consult SDS sheet for hazards information. Be aware that some materials are explosive as a dust.

4.28 DO NOT OVERREACH.

Keep proper footing and balance at all times.

4.30 MAINTAIN MACHINE WITH CARE.

Keep machine clean and follow maintenance procedures for better and safer performance. Keep handles dry, clean, and free from oil and grease. Follow instructions for lubricating and changing accessories.

4.31 REMOVE ADJUSTING TOOLS.

Form a habit of checking to see that tools such as adjusting wrenches are removed from the machine and properly stored before starting the engine.

4.32 STAY ALERT.

Watch what you are doing. Use common sense. Do not operate machine when you are tired or fatigued.

4.33 DO NOT USE DRUGS, ALCOHOL, MEDICATION.

Do not operate machine while under the influence of drugs, alcohol, or any medication.

4.34 KEEP THE RIGHT PARTS IN THE RIGHT POSITIONS.

Do not operate machine with parts missing or improperly mounted.

4.35 CHECK DAMAGED PARTS.

Verify all machine guards are in good condition and will function properly before using the machine. Check for alignment of moving parts, binding of moving parts, breakage of parts, mounting, and any other conditions that may affect machine operation. A guard, power switch or other part that is damaged should be properly repaired or replaced by an authorized service center unless indicated elsewhere in this instruction manual. Do not operate machine if lever or engine on/off switch does not function properly.

4.36 SECURELY MOUNT ACCESSORIES AND BLADES TO THE MACHINE.

Extra care must be taken when using saws on an elevated location to prevent injury to someone on a lower level in the event the tool or accessory should drop. Do not operate without fall protection for operator and debris protection for public.

4.37 NEVER TOUCH THE MOVING PARTS.

Never touch moving parts such as blades, belts and others.

4.38 STOP OPERATION IMMEDIATELY IF ANY ABNORMALITY IS DETECTED.

Stop using machine immediately if any abnormalities are observed during operation. Examples of abnormalities include unusual noise and vibration.

4.39 WHEN REPLACING A PART, USE THE SAME TYPE AND QUALITY.

When replacing a component part with a new one, use only the same type and quality of new part. Never attempt to repair a machine if you are unfamiliar with proper procedures and techniques required.

4.40 NEVER DISABLE THE LEVER.

Do not modify, disable, or attempt to permanently engage the lever. Do not operate a machine if lever is not functioning. This could lead to serious injury or death.

4.41 LOAD AND UNLOAD SAFELY.

Use proper heavy lifting procedures. Read & understand manuals before loading & unloading.

4.42 STORAGE.

Always store equipment properly when it is not being used. Equipment should be stored in a clean, dry location and out of reach of children.

4.43 SAVE THESE INSTRUCTIONS.

Refer to this operations and maintenance manual as well as any additional instructions included from other manufacturers and organizations such as the Masonry and Concrete Saw Manufacturers Institute®. Never permit anyone to operate the machine without proper instructions.



DUST WARNING

Cutting, especially when DRY cutting, generates dust that comes from the material being cut, which frequently contains silica.

Silica is a basic component of sand, quartz, brick clay, granite and numerous other minerals and rocks. Exposure to excessive amount of such dust can cause:

- Respiratory diseases (affecting your ability to breath), including chronic bronchitis, silicosis and pulmonary fibrosis from exposure to silica. These diseases may be fatal;
- Skin irritation and rash; and
- Cancer according to NTP* and IARC*

* National Toxicology Program, International Agency for Research on Cancer

Take precautionary steps

- Avoid inhalation of and skin contact with dust, mist and fumes;
- Wet cut when feasible, to minimize dust;
- Wear and ensure that all bystanders wear appropriate respiratory protection such as dust masks designed to filter out microscopic particles. (See OSHA 29 CFR Part 1910.1200)

California Prop 65 Warning: Use of this product can cause exposure to materials known to the State of California to cause cancer and/or birth defects or other reproductive harm.



PRE-OPERATION CHECKLIST

5.0 PRE-OPERATION CHECKLIST



Read and understand operator's manual before using this machine. Failure to follow operating instructions could result in injury or damage to equipment.

Figure 1 - Warning label - read and understand manual

5.1 Start by reading the entire Manufacture Engines Owner's Manual, Rx for Diamond Blade Safety, and Rx for Concrete Saws by the Masonry and Concrete Saw Manufacturers Institute. Then, read the entire JS operations and maintenance manual. Get familiar with the machine's parts. See Figure 1 through Figure 32.

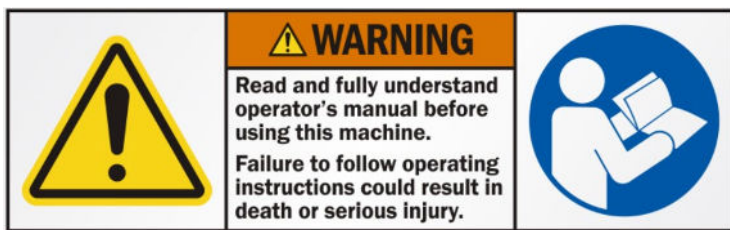

TO PREVENT SERIOUS INJURY DO NOT OPERATE SAW WITHOUT PROPER TRAINING AND UNDERSTANDING OF THE OWNERS MANUAL WHEN OPERATING THIS MACHINE

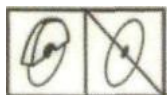

Keep all guards in place



Wear Head Protection, breathing protection, and the use of hearing protection is mandatory



Flying debris and loud noise hazards. Wear ear and eye protection



Wear hand protection



WARNING: Improperly maintaining the JS including the manufacture engine or failing to correct a problem before operation could cause a malfunction resulting in a serious injury. Always perform a pre-operation inspection before each operation and correct any problem. See Manufacture Engines Owner's Manual.

5.2 Check the condition of the manufacture engine. See the section titled "Before operation - is your engine ready to go?" in the Manufacture Engines Owner's Manual.



AVOID STATIC ELECTRICITY RISK

WARNING: Ultra-Low Sulfur Diesel (ULSD) poses a greater static ignition hazard. Consult with your propane supplier to ensure the delivery system is in compliance with fueling standards for proper grounding and bonding practices. Maintaining a discharge strap must be connected to any U.S.SAWS vacuum at all times when equipment is being used.



Wear proper electrostatic grounding equipment at all times. Static discharge during can cause explosion



WARNING: Exhaust gas engines contains dangerous carbon monoxide. Breathing it can cause unconsciousness and even kill you. Always operate in a well-ventilated area. Do not operate in areas where exhaust fumes could accumulate without wearing appropriate respiratory protection. Consult your employer and OSHA regarding use of appropriate respirator for dangerous carbon monoxide gases. See Figure 7.



Engine exhaust contains poisonous carbon monoxide gas. Breathing it could cause death. Operate machine in well ventilated area.

Figure 2 - Warning label - engine exhaust contains carbon monoxide gas 11

5.3 Observe the condition of your work environment. Walk over area work area and look for hazards. Make sure the work environment is safe and meets all safe-working conditions discussed in section 4, Rules for safer operation.

5.4 Obtain SAFETY DATA SHEET (SDS) for all work surface materials. This includes primers, all coatings, adhesives, tile and crack filling materials, etc. Do not attempt to cut, clean out, or remove material without SDS information. Consult SDS sheet for health hazards information. Be aware that some materials are explosive as a dust



WARNING: The JS-160 SAWS maximum blade operating speed is 5,850 rpm as labeled on the blade guard. Use only dry cut diamond blades rated higher than 5,850 rpm safe operating speed. Do not use a blade rated for less than 5,850 rpm. Do not use a blade that is not a dry cut diamond blade. Using a non dry cut diamond blade or a blade rated below 5,850 rpm could result in severe blade failure, personal injury or death. See Figure 8 and Figure 9. Never cut material for which the blade was not designed. Check blade manufacturer's guidelines on material to be cut. Never operate a blade in the wrong rotation direction. Verify blade direction when changing blades. The JS is designed to cut in a straight line. Never attempt to cut any pattern or follow any joint that is not a straight line.



PRE-OPERATION CHECKLIST

5,850 MAX. RPM

Figure 3 - Max rpm label - maximum blade speed

5.5 Choose the proper dry cut diamond blade for the application, speed and material to be cut. See Figure 9.



Use only diamond blades (steel centered diamond cutting-off wheels) with this machine. RPM rating on blade must exceed machine max rpm rating. The use of any other blade could result in death or serious injury.

Figure 4 - Warning label - use only diamond blades

5.5 Clearly mark all intended cut areas with straight paint or chalk lines.

5.6 Verify that the lever is disengaged or released, and the engine switch and fuel valve lever are in the OFF position. Make sure blade is completely stopped.



CAUTION: Running the JS generates heat in the engine, blade and blade guard. Do not touch these components without wearing proper heat protecting work gloves.

5.7 Remove bolt in the blade guard holding bracket. Hold the blade guard firmly and raise guard up into the holding bracket. Reinsert bolt in the blade guard holding bracket and tighten nut.

5.8 Remove both blade change wrenches from the JS handle. Install dry cut diamond blade. See section 7.1 for detailed instructions on removing and installing blades. Inspect diamond blades for damage at least twice daily and before each use. Damaged diamond blades are hazardous and should never be used on a JS.



TO AVOID INJURY.

Always inspect saw blades before use. Replace all cracked or damaged blades.

Figure 5 - Warning label - inspect blades before use

5.9 Replace the wrenches in the holding bracket on the handle. Tighten the wrench-clamping knob.

5.10 Check the belt tension each day before starting work. Check after the first hour of operation if the JS or belt is new. See section 7.3 for detailed instructions on checking and adjusting the belt tension.

5.11 Move the front and rear pointer arms down towards the ground. Turn the height adjustment handle clockwise until the blade touches the ground. Now turn the adjustment handle counter-clockwise one complete 360° turn. This will raise the blade slightly off the ground.

5.12 Using the marked chalk line or any straight line on the ground, align the blade with the line. On the pointer wheels, loosen the adjustment nuts and align the wheels with the same chalk line. Push the JS along the line to verify the alignment is straight. See Figure 11 and Figure 12.

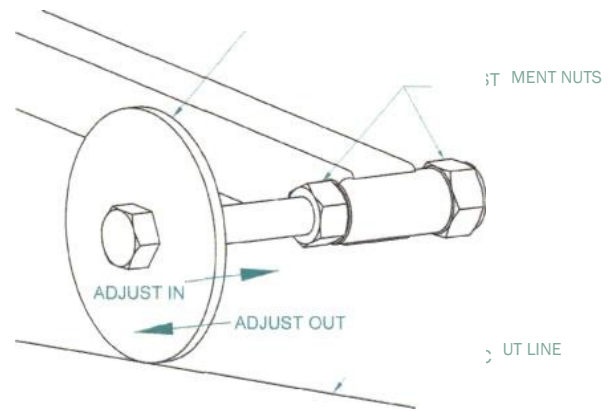

Figure 6 - Pointer wheel adjustment

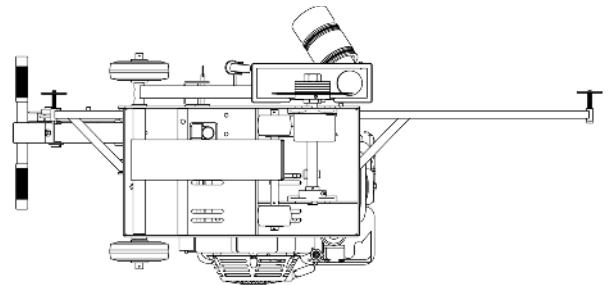

Figure 7 - Alignment of blade and the pointer wheels - JS bottom view



PRE-OPERATION CHECKLIST

CAUTION

CAUTION: The blade depth is approximate and not exact. Many variables affect the exact blade depth such as the exact diameter of a worn diamond blade. If an accurate depth must be cut, install the blade to be used with the engine in the OFF position. Place the JS in a secure position that allows the blade to overhang and be visibly measured at full blade depth. An example would be blocking the wheels with the engine in the OFF position and lowering the JS blade along side a street curb. This will allow a measurement from the bottom of the blade to the top of the curb.

5.14 Hold the blade guard firmly and remove the bolt in the blade guard holding bracket. Lower the blade guard down until the 2" caster wheel touches work surface. Reinsert bolt in the blade guard holding bracket for future use.

5.15 Make sure the blade guard caster wheel and white dust urethane seal at the blade guard base are firmly touching the work surface. See section 7.2 for detailed instructions on adjusting the dust urethane seal and urethane seal guard caster wheel.

WARNING

WARNING: Breathable silica may be generated by use of this product. Silica can cause severe and permanent lung damage, cancer, and other serious diseases. Do not breathe the dust. Do not rely on your sight or smell to determine if the dust is in the air. Silica may be in the air without a visible dust cloud. If air monitoring equipment for silica is not provided by your employer at your work site, you **MUST** wear appropriate respiratory protection when using or servicing the machine. Consult your employer and OSHA regarding the appropriate respiratory protection.

5.16 Slide the 3" diameter vacuum hose over the connector and tighten the worm drive hose clamp. Pull firmly on the hose to verify the connection will not slide off.

5.17 Check for missing or loose bolts. Tighten loose bolts and replace missing bolts before operating machine. Verify that belt and blade guards are in place. Never operate a JS without guards in place. See Figure 14 and Figure 15.

WARNING

5.18 **WARNING:** If you can see the drive belt or diamond blade, the guards are not in place. Never operate a JS without guards in place. The proper position for the belt guard is bolted with four bolts to the chassis. The proper position for the blade guard is down with the white guard dust brush touching the horizontal surface. See Figure 14 and Figure 15.

5.19 Dress properly. Wear ear and eye protection. See sections 4.3 through 4.7. See Figure 16

5.20 JS premium dry cut diamond blades, medium bond

WARNING

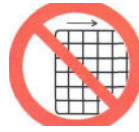

AVOID INJURY.

Do NOT operate with guard removed. Replace guard before operating machine.

Figure 8 - Warning label - do not operate with guard removed



Rotating blade hazard. Do NOT operate with guard up. Keep hands and feet away.

Figure 9 - Warning label - do not operate with guard up

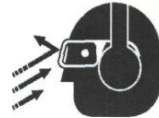

Flying debris and loud noise hazards. Wear ear and eye protection



Wear appropriate clothing

Figure 10 - Warning label - wear proper clothing, ear and eye protection

WARNING

WARNING: Recommended accessories for this tool including blades are listed in this manual or are available by calling customer service. The use of any other attachment or accessory might be hazardous

Table 6 - Dry Cut Diamond Blade List*

(* All blades listed are designed with JS drive pin holes and 1" diameter arbor holes.)

CLEANING	DEPTH OF JOINT	SIZE	JOINT WIDTH (INCHES)			
			1/8 - 3/16	3/16 - 3/8	3/8 - 1/2	1/2 or more
Up to 2" Deep	8"	.095, .125, .187	.187, .250, .375	.375, .500	.095 + spacers	
		HARD	HARD	HARD	HARD	
Up to 3" Deep	10"	.095, .125, .187	.187, .250, .375	.375, .500	.095 + spacers	
		HARD	HARD	HARD	HARD	

REMOVAL	DEPTH OF JOINT	SIZE	JOINT WIDTH (INCHES)			
			1/8 - 3/16	3/16 - 3/8	3/8 - 1/2	1/2 or more
Up to 2" Deep	8"	.095 x 8 .125 x 8 .187 x 8	.187 x 8 .250 x 8 .375 x 8	.375 x 8 .500 x 8	.095 + .060 spacer x 8	
		MEDIUM	MEDIUM	MEDIUM	MEDIUM	
		Up to 3" Deep	10"	.095 x 10 .125 x 10 .187 x 10	.187 x 10 .250 x 10 .375 x 10	.375 x 10 .500 x 10
MEDIUM	MEDIUM			MEDIUM	MEDIUM	

CUTTING	DEPTH OF JOINT	SIZE	JOINT WIDTH (INCHES)			
			1/8 - 3/16	3/16 - 3/8	3/8 - 1/2	1/2 or more
Up to 2" Deep	8"	.095 x 8 .125 x 8 .187 x 8	.187 x 8 .250 x 8 .375 x 8	.375 x 8 .500 x 8	.095 + .060 spacer x 8	
		SOFT	SOFT	SOFT	SOFT	
		Up to 3" Deep	10"	.095 x 10 .125 x 10 .187 x 10	.187 x 10 .250 x 10 .375 x 10	.375 x 10 .500 x 10
SOFT	SOFT			SOFT	SOFT	



6.0 OPERATION

The **U.S.SAWS JS -Series** saws are designed for the purpose of:

- Cleaning out existing control joints
- Removing existing joint fill material
- Cutting concrete to remove deteriorated concrete for joint rebuilding

Each one of these tasks is unique in nature and require different blade configurations.

Cleaning our existing joints:

After the early entry saw makes it's cut, and the slab cures and construction commences, there is usually a lot of debris and dust in the exposed control joint. This debris and all the concrete dust / dry slurry needs to be removed, and the sidewalls of the joint need to be prepared to allow proper placement and adhesion of the joint fill material. The dust and debris are very abrasive, and the best choice of blade is a U.S.SAWS supreme grade blade of the appropriate width. The width should be determined by the actual width of the joint and the engineering specifications for the joint. Keep in mind, as the slab contracts during the curing process; some joints might be wider than others. U.S.SAWS advises that the contract always has several widths of blades on hand at all times. US Saws provides blades in the following sizes and widths: 8, 10 inches in diameter .095, .110, .125, .187, .250, .375, .500 inches in width. The blade should fit snugly and touch both sides of the joint. The joint cleanout process will be significantly slower if the joint is being "over cut" in size, width, and or depth. In some cases, more than one blade can be placed side by side to achieve a specific width. Example: (2) .110 thickness blades will achieve an overall cutting width of .220.

Joint fill Removal:

There are typically three types of joint fill materials removed with this machine.

- Epoxy (semi-rigid)
- Polyurea
- Polyurethane

Joint fill removal can be a difficult task and is highly dependent on a variety of variables.

Epoxy joint fill is, in most cases, able to be cut with a U.S.SAWS Supreme Grade Diamond Blade. The blade width should be as close as possible to the width of the existing filled joint. The depth of cut should be determined by the engineering standard of the intended use of the floor. Example: Hard wheel and heavy forklift traffic will usually require a full depth cut, soft pneumatic wheel traffic or strictly foot traffic may only require partial depth removal. Consult the joint fill manufacturer for best practices with the specified material.

Polyurea is much more difficult to cut than epoxy and will typically require a U.S.SAWS Tigertooth Blade or U.S.SAWS PCD Poly Shredder Blade.

- Tigertooth blades are meant to remove joint fill material but NOT to over cut a joint in width or depth.

*Care should be taken by the operator to not force the saw through the polyurea, which will create excessive heat and slow performance.

- PCD Poly shredder blades are designed to be used for "cap and fill" projects where only about ½ inch of depth is required. Bottoming out this blade in the joint will destroy the PCD segments.

Polyurethane is the typical material used in waterproofing of parking

garages, bridge joints and cold joints on large slabs like airport tarmac. Removal of this material can be most efficiently achieved by using a thin U.S.SAWS Supreme Concrete Blade and making a cut on the edge of the surface where the polyurethane meets the concrete. The inside of the blade will be touching the polyurethane, and the outside edge will be touching concrete. Most of these applications have a foam backer rod in the bottom of the joint, and cutting both sides will allow easy manual removal of the rest of the joint fill material being removed.

Cutting Concrete

While cutting concrete is easily achievable with the U.S.SAWS JS-Series saws, please make sure your expectations are realistic in conjunction with the task being performed. Some factors of performance are:

- More depth equals less cutting speed.
- More Blade Width equals less cutting speed
- Up-cut saws are slower cutting than Down-cut saws
- This saw should not be expected to have the same cutting speed as a 35 hp pro saw.
- Dry cutting is typically slower than wet cutting. This saw is designed to cut dry with a vacuum system attached at all times. Knowing the above information can help keep performance expectations reasonable.

Concrete slabs can be very different from one job to the next, and aggregate hardness can vary dramatically based on regional or specified raw materials in the concrete mix. Please refer to the aggregate hardness chart as a general guide. In extreme cases, a core sample of the concrete may need to be taken and analyzed. (This is common in the professional concrete cutting industry) Example: Some concrete has specified granite or river rock aggregate that can make cutting it very difficult.

Quick Guide:

Soft Concrete: If blades are wearing out quickly, the concrete is likely very abrasive, and a Hard Bond blade should be used.

Medium concrete (most common): Any of the U.S.SAWS Supreme, Premium or Standard blades should work.

Hard Concrete: Hard concrete is the concrete that gives most people problems. The symptoms below will give you an indication that the blade being used is too hard, and the operator should switch to a "softer bond" blade.

- The blade is heating up and looks like it has burn marks on it.
- The blade is cutting for a short distance and then stops cutting.
- There are excessive sparks being generated by the blade.



OPERATION

- 6.1 Follow all pre-operating instructions in section 5.0.
- 6.2 Turn handle counterclockwise until jack assembly upper arm is above the highest depth slot. This will allow proper clearance between the work surface and the blade tip.

WARNING

WARNING: Never attempt to start the engine with the diamond blade inserted in a joint or previous cut. The blade will turn as soon as the JS is started. This could damage the blade or cause the JS to jump backwards.

- 6.3 Turn on the vacuum system.
- 6.4 Move the engine fuel valve lever to the ON position.
- 6.5 To start a cold engine, move the choke lever to the CLOSED position. To restart a warm engine, leave the choke lever in the OPEN position.
- 6.6 Move the throttle lever away from the SLOW position, about 1/3 of the way toward the fast position.
- 6.7 Turn the engine switch to the ON position.
- 6.8 Stand on the side of the JS opposite the blade guard. With the left hand, pull the starter cord grip lightly until you feel resistance, then pull briskly. Return the starter grip gently. Repeat until engine starts. If engine does not start, see section 7.5 for maintenance.
- 6.9 If the choke lever has been moved to the CLOSED position to start the engine, gradually move it to the OPEN position as the engine warms up.
- 6.10 While continuing to squeeze the lever, switch the right hand with the left hand. In other words, your left hand will now be on the left handle grip and squeezing the lever. This will free your right hand. Warren to provide new copy.
- 6.11 Using your left hand on the handle pull back and downwards on the handle to reduce the weight on the front wheels while at the same time using your right hand to release the depth stop and gently lower the lifting handle the blade into the joint.
- 6.12 Cut with the machine for a few inches. Pull back on the handle with your left hand in the same way as 6.11 above while at the same pulling back on the lifting hand, then release the lock so the machines rest out of the cut then turn the machine off.
- 6.13 Measure the depth of cut and adjust as necessary.

WARNING

WARNING: Do not twist the blade in the cut. Never attempt to cut any pattern or follow any joint that is not a straight line. Do not force the blade forward. These actions could damage the blade and JS unit.

- 6.14 Proceed to clean out the joint as required. Remove blade from the cut as described in 6.12.
- 6.15 In the event of an emergency related to the blade, step to the left of the machine and turn the Motor OFF if possible.

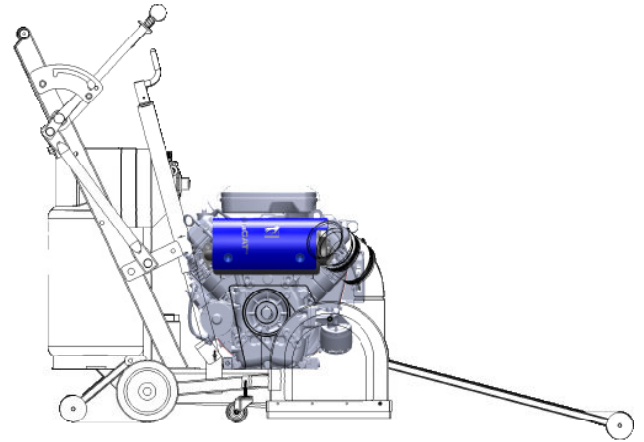

Figure 11-JS SERIES SAWS in cutting operation (Operator wearing personal protective equipment and dust collector are not shown)

WARNING

WARNING: Beware that after releasing the lever, the blade will continue spinning for several seconds. Keep a firm hold on the handle grips and maintain control of the machine until the blade completely stops.

- 6.16 For normal shut down. Pull the saw blade out of the cut by pulling back on the handle with your left hand, while at the same pulling back on the lifting handle, then release the lock so the machines rest out of the cut then turn the machine off.
- 6.17 For any other emergency, such as fire, use the normal procedure above, 6.16, to pull the saw blade out of the cut.



PARTS BREAKDOWN

6.18 Figure 18 to Figure 23 of JS SERIES SAWS

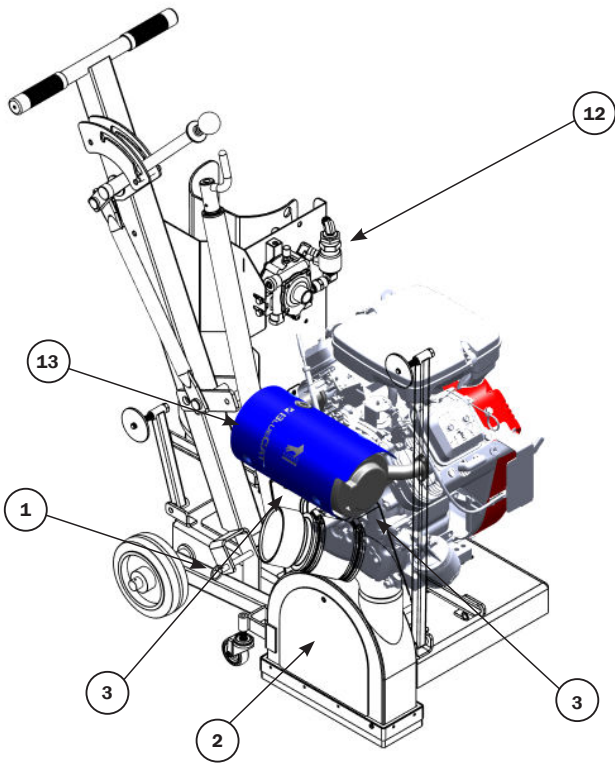

Figure 12 - JS SERIES SAWS top front right view

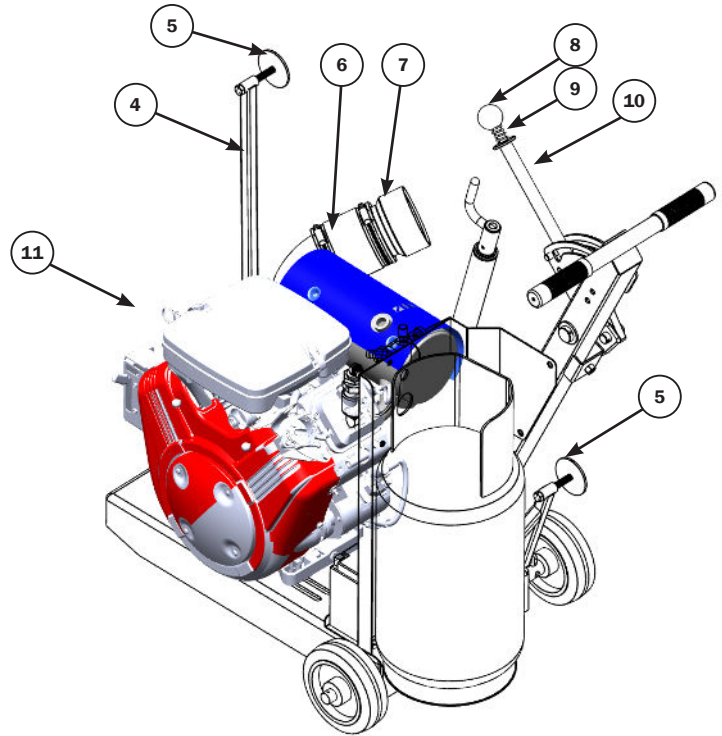

Figure 13 - JS SERIES SAWS top rear left view

ITEM	QUANTITY	PART NUMBER	DESCRIPTION
1	1	SX77158	3/8" X 3" QUICK RELEASE PIN
2	1	SX77138	BLADE GUARD DUST COVER
3	1	SX77136	BELT GUARD
4	1	SX78116	POINTER ARM 24"
5	2	SX78119	POINTER WHEEL
6	1	SX90210	3"X3" RUBBER COUPLER
7	1	SX77148	ADAPTER/3"
8	1	SX90193	BALL KNOB
9	1	SX73706-1	KNOB SPRING
10	1	SX77030	JS DEPTH HANDLE LOCK
11	1	SXGX390-505	AIR FILTER
12	1	SXVG479FC	FUEL CONVERSION KIT
13	1	SXVG479MUF	MUFFLER CATALYTIC



PARTS BREAKDOWN

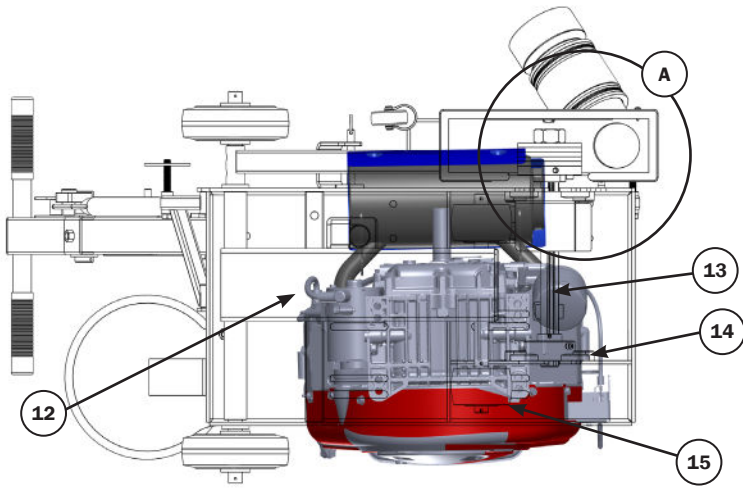

Figure 14 - JS SERIES SAWS bottom view

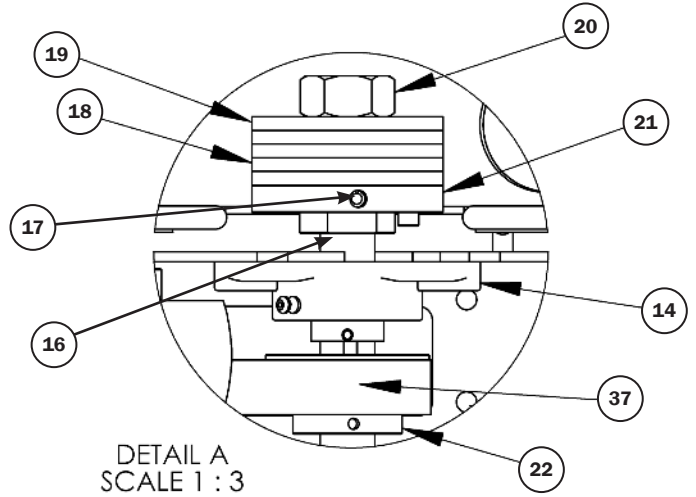

Figure 15 - JS SERIES SAWS with flange detail

ITEM	QUANTITY	PART NUMBER	DESCRIPTION
12	1	SX77127	FRAME/FRONT AXLE
13	1	SX77024	BLADE SHAFT 1"
14	2	SX90177	BEARING/FLANGE 2 BOLT 1" BORE
15	2	SX77021	WHEEL/3"X1-13/16"
16	1	SX77024	BLADE SHAFT 1"
17	1	US31329	5/16" X 3" ROLL PIN
18	4	SX80502	JS 1/4" SPACER
19	1	SX80501	JS OUTER FLANGE W/PIN
20	1	SX80504	1"-14 BLADE NUT
21	1	SX80503	JS DRIVE FLANGE
22	1	SX50162	3 VX SHAFT PULLEY



PARTS BREAKDOWN

Figure 16 - JS SERIES SAWS with belt and flange details
 (Shown without belt guard, item #3, and blade guard, item #2.
 Never run a JS without both guards in place.)

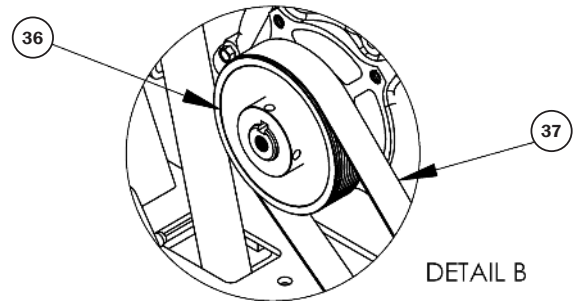
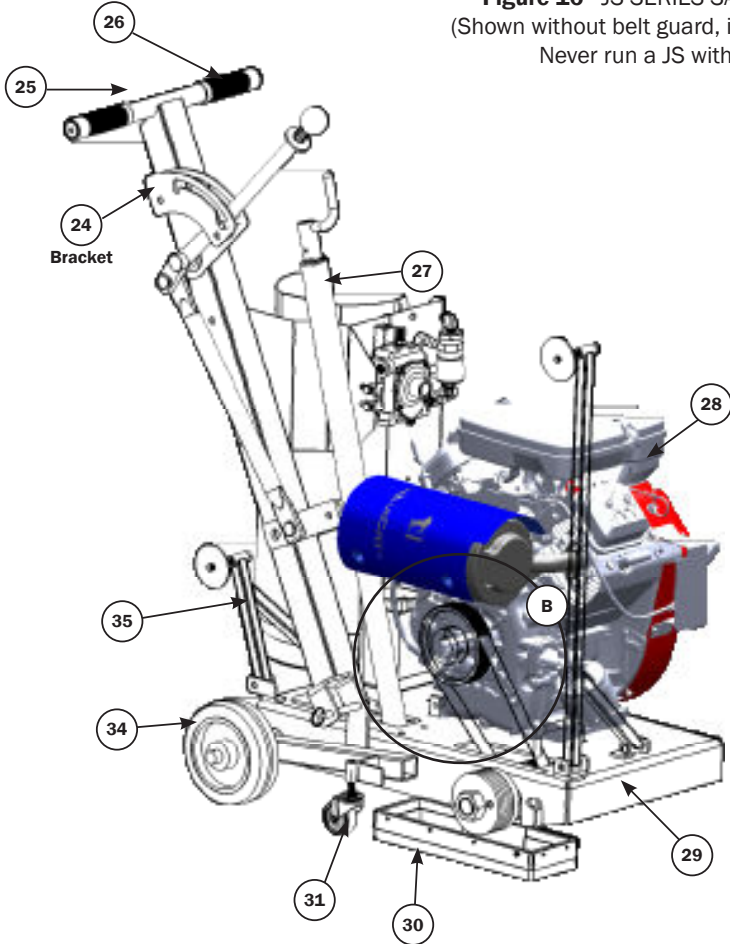

JS-160 Belts/ Pulleys		
MACHINES BUILT BEFORE 4/15/2021		
US24600-80	MOTOR PULLEY	1
SX92026-4	SHAFT PULLEY	1
SX92018	300J10 BELT	1
MACHINES BUILT AFTER 4/15/2021 (current model)		
SX50165	3VX MOTOR PULLEY	1
SX50162	3VX SHAFT PULLEY	1
SX50171	3VX300 BELT	2

ITEM	QUANTITY	PART NUMBER	DESCRIPTION
24	1	SX90160-3	JS SAW OUTER DEPTH ADJUSTMENT QUADRANT
25	1	SX77141	HANDLE
26	1	US32404	RIBBED HANDLE GRIP
27	1	SX77162C	JACK ASSEMBLY
28	1	SXVG479	16 HORSEPOWER VANGUARD ENGINE
29	1	SX77120C	CHASSIS
30	1	SX77126	BLADE GUARD SKIRT KIT
31	1	SX60184	2"HR 3/8"-16 STEM CASTER
34	1	US30042	6" HARD RUBBER WHEEL
35	1	SX77116	ARM/POINTER 7"
36	1	SX50165	3 VX MOTOR PULLEY
37	2	SX50171	3 VX 300 BELT



MAINTENANCE AND INSPECTION

7.0 MAINTENANCE AND INSPECTION



WARNING: Release or disengage the turn the engine switch to the OFF position, and turn the fuel valve lever to the OFF position before performing any maintenance and inspection. This will be referred to as the JS OFF position in sections 7.1 through 7.7.



WARNING: Damaged diamond blades are hazardous and should never be used on a JS. Inspect diamond blades at least twice daily and before each use for signs of damage.



TO AVOID INJURY.

Always inspect saw blades before use. Replace all cracked or damaged blades.

Figure 17 - Warning label - inspect blades before use



CAUTION: Running the JS generates heat in the engine muffler, blade and blade guard. Do not touch these components without proper heat protecting work gloves.

7.1 Removing and installing the blade

7.1.1 With engine in the OFF position, loosen the clamping knob and remove both 1-1/2" blade change wrenches from the JS handle.

7.1.2 Remove bolt in the blade guard holding bracket. Hold the blade guard firmly and raise guard up into the holding bracket. Reinsert bolt in the blade guard holding bracket and tighten nut. See Figure 27.

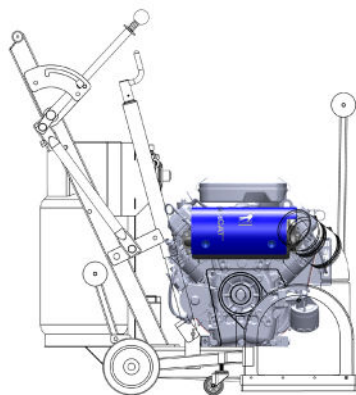

Figure 18 - JS in blade change position with engine off (Never start engine or run JS in this position)

7.1.3 Place one wrench on the drive flange to hold the blade shaft in place. Place the other wrench on the blade nut and turn counter-clockwise to loosen the nut.

7.1.4 Unscrew the blade nut. Slide the outer flange, spacers and blade off the shaft.

7.1.5 Replace blade, spacers, and outer flange. Outer flange pin must line up with all spacers and drive flange to fit through properly.



WARNING: Be sure that the flanges, spacers, and blade are clean and undamaged before mounting. Do not use damaged parts. The JS maximum blade operating speed is 5850 rpm as labeled on the blade guard. The JS shaft diameter is 1 inch. Therefore, only use dry cut diamond blades rated for higher than 5850 rpm maximum safe speed and designed for 1-inch diameter shafts. Using a non dry cut diamond blade or a blade rated below 5850 rpm could result in severe blade failure, personal injury or death. See Figure 28 and Figure 29. Never cut material for which the blade was not designed. Check blade manufacturer's guidelines on material to be cut. Never operate a blade in the wrong rotation direction. Verify blade direction when changing blades.

5850 RPM

Figure 28 - Max RPM label - maximum blade speed



2 Hazard Communication Systems, LLC
800-746-0241

Reorder No. HSOU-369WHPL

Use only diamond blades (steel centered diamond cutting-off wheels) with this machine. RPM rating on blade must exceed machine max rpm rating. The use of any other blade could result in death or serious injury.

Figure 19 - Warning label - use only diamond blades

7.1.6 Spacers can be removed to allow room for the blade thickness.

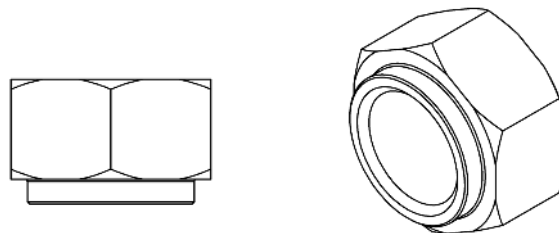

Figure 20 - Blade nut face must be flat against outer flange



MAINTENANCE AND INSPECTION

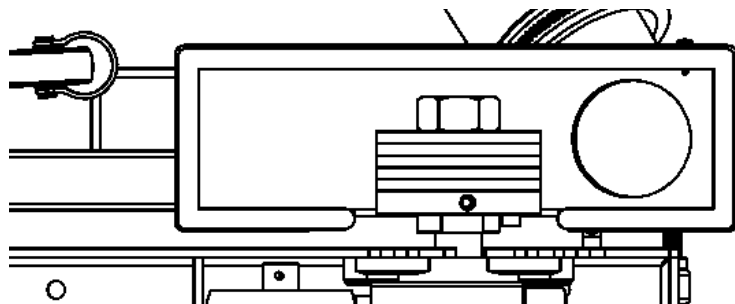

Figure 21 - Blade, spacers, and flanges set up
(Note: Shown with one spacer removed)

7.1.7 Screw on and tighten the blade nut with wrenches making sure the face is flat against the outer flange. The blade shaft should be flush or slightly stick out beyond the blade nut to ensure all the blade nut threads are engaged. The outer flange pin should not touch the JS chassis and 1/2" hex bolts when rotating. Rotate blade by hand to verify proper clearance and that the blade runs true (without wobbling). See Figure 30 and Figure 31. Never use a blade with interference or that does not run true.

7.1.8 Lift up on blade guard and remove bolt in blade guard holding bracket. Lower the blade guard down. Reinsert bolt and tighten nut to prevent vibration. Always run a JS with the blade guard in the down position.



WARNING: Breathable silica may be generated by use of this product; Silica can cause severe and permanent lung damage, cancer, and other serious diseases. Do not breathe the dust. Do not rely on your sight or smell to determine if the dust is in the air. Silica may be in the air without a visible dust cloud. If air monitoring equipment for silica is not provided by your employer at your work site, you **MUST** wear appropriate respiratory protection when using or servicing the machine. Consult your employer and OSHA regarding the appropriate respiratory protection.

7.2 Adjusting dust brush height and 2 inch blade guard caster wheel

7.2.1 The 2-inch caster wheel on the right side of the blade guard controls the dust brush height. The dust brush should firmly touch the ground to prevent excessive dust from escaping into the surrounding work area.

7.2.2 With engine in the OFF position, loosen the 3/8-inch hex nut by turning it clockwise. Then turn the caster adjustment nut counterclockwise to lower the dust brush or clockwise to raise the dust brush.

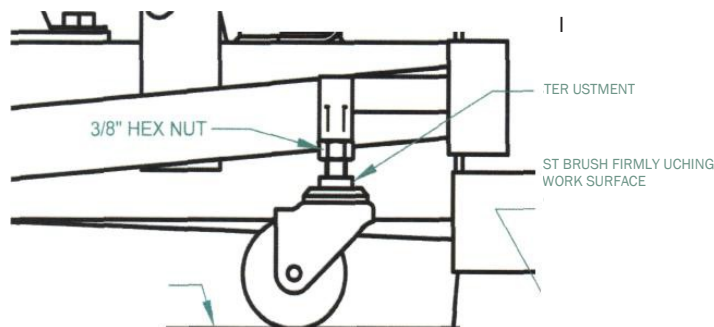

Figure 22 - Blade guard caster wheel adjustment

7.2.3 With the dust brush in the desired position, tighten the 3/8-inch hex nut by turning it counterclockwise.

7.3 Checking and adjusting belt tension

7.3.1 The belt tension should be checked after the first hour of operation on a new JS or new belt. On a used JS, the belt tension should be checked once a day. With engine in the OFF position, remove the four 5/16" hex bolts that attach the belt guard to the chassis.

7.3.2 Remove the belt guard. The belt should deflect no more than 1/16" under moderate finger pressure equidistant between the sheaves.

7.3.3 To tighten the belt, loosen the four 5/16" hex nuts that hold the engine to the chassis. Then, turn the 3/8" hex head bolt clockwise on the front of the JS. This bolt can be seen as item #44 in Figure 18.

7.3.4 After reaching the desired belt tension, verify that the belt sheaves are properly aligned and the belt is straight. Retighten the four 5/16" hex nuts that hold the engine against the chassis.

7.3.5 Replace the belt guard with the four 5/16" hex bolts that were removed in step 7.3.1. Never run a JS without the belt guard in place.

7.4 Bearing lubrication

7.4.1 With engine in the OFF position, slowly tilt the JS back until the handle rests on the ground.

7.4.2 These bearings are exposed to excessive dust and require the same brand of high quality grease as supplied by the factory. Apply ALVANIA® Grease 3 with a hand grease gun to both flanged bearings on the blade shaft after every 100 hours of use.

7.4.3 The performance of the bearing is greatly influenced by the quantity of grease. For optimum performance, insert grease until a little bleeds out from between the outer ring raceway and the perimeter of the slinger. Wipe off excess grease.

7.4.4 Slowly tilt the JS forward until all wheels are back on the work surface.

7.5 Engine maintenance

7.5.1 See the section titled "Servicing your engine" in the Manufacture Engines Owner's Manual. This section includes detailed information on:

7.5.1.1 The importance of maintenance

7.5.1.2 Maintenance safety and precautions

7.5.1.3 Maintenance schedule

7.5.1.4 Refueling

7.5.1.5 Engine oil level check, oil change, and recommendations

7.5.1.6 Air filter inspection

7.5.1.7 Air cleaner service

7.5.1.8 Sediment cup cleaning

7.5.1.9 Spark plug service

7.5.1.10 Idle speed adjustment

7.6 Transportation

7.6.1 Allow the JS blade guard, blade, engine, and engine muffler to cool.

7.6.2 See the section titled "Helpful tips and suggestions - Transporting" in the Engines Owner's Manual.

7.6.3 With engine in the OFF position, securely strap down JS to shipping pallet, trailer bed, etc. in normal upright position.

7.7 Trouble shooting

7.7.1 See the three sections titled "Helpful tips and suggestions, Taking care of unexpected problems, and Technical and consumer information" in the Manufacture Engines Owner's Manual.

7.7.2 See Rx for Diamond Blade Safety by the Masonry and Concrete Saw Manufacturers Institute for diamond blade troubleshooting.



PROPANE POWER SYSTEM

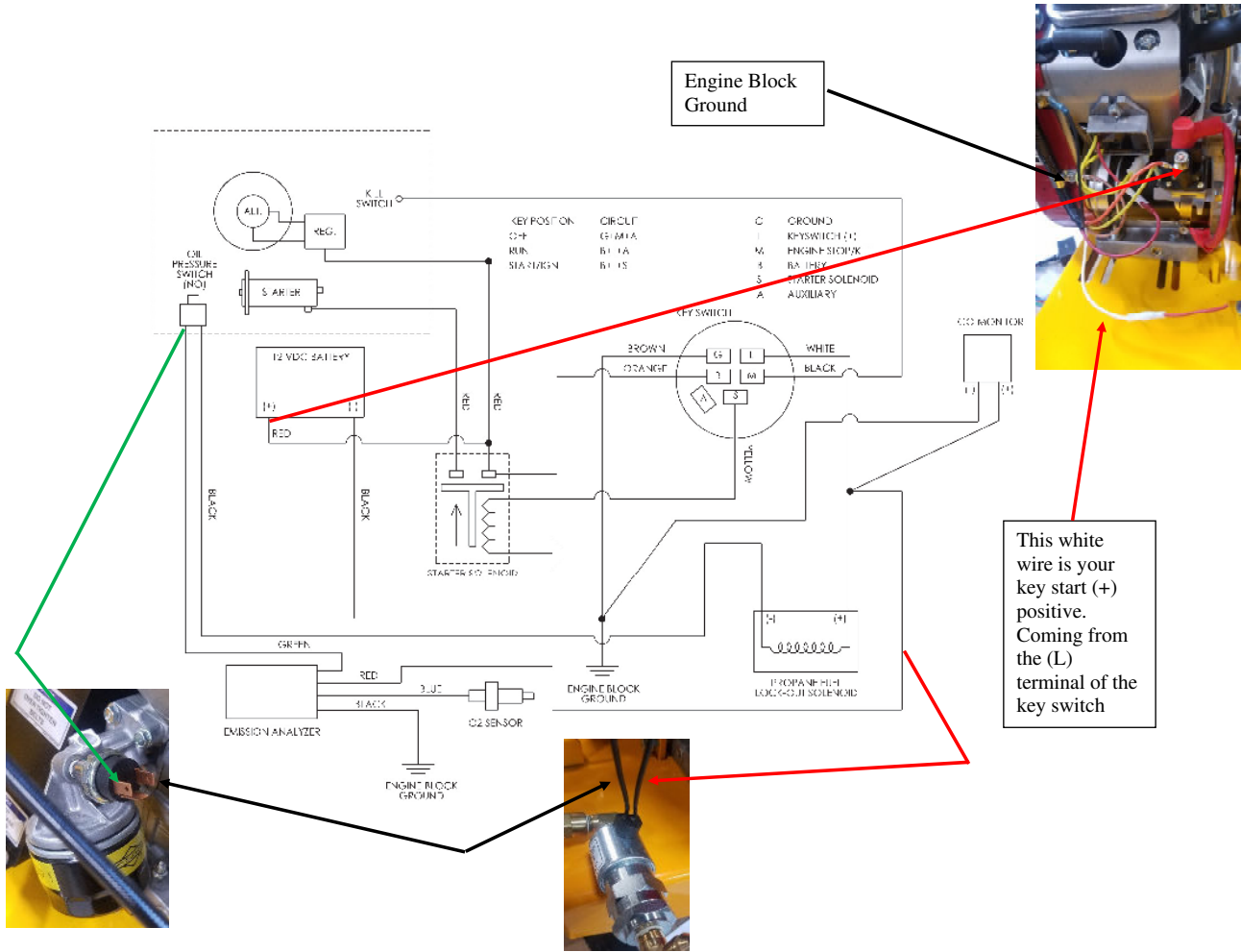

Figure 23- JS 160 Propane wiring Diagram



WARRANTY AND SERVICE

8.0 WARRANTY AND SERVICE

8.1.1 Warranty

This document is to be used as a guide in determining warranty policies and procedures for U.S.SAWS and its U.S.SAWS products. It is to be used in determining whether a warranty is justified and as a procedural guide in completing a U.S.SAWS warranty claim form.

8.1.2 Warranty Responsibility

The distributor or the end user must prepare a Machine Warranty Information Card when the machine is delivered. Failure to comply will make any and all warranties on this equipment null and void. Credit for warranty repairs will be given only after receipt of the WARRANTY CLAIM FORM, properly completed with all the required details. Submittal details are described later in this document.

8.1.3 Warranty Policy

8.1.3.1 U.S.SAWS warrants its U.S.SAWS products against defects in material and workmanship under normal and proper use for a period of one year (365) days from the date of delivery; in the case of Rental Fleet Machines, date of assignment to Rental Fleet. Such warranty is extended only to the buyer who purchases the equipment directly from U.S.SAWS or its authorized distributor. This warranty does not include expendable parts such as, but not limited to, plugs, cutters, blades, blast wheel, wear parts, liners and seals.

8.1.3.2 The obligation under this warranty is strictly limited to the replacement or repair, at U.S.SAWS's option, of machines and does not include the cost of transportation, loss of operating time, or normal maintenance services.

8.1.3.3 This warranty does not apply to failure occurring as a result of abuse, misuse, negligence, corrosion, erosion, normal wear and tear, alterations or modifications made to the machine without express written consent of U.S.SAWS .

8.1.3.4 Warranty request must be submitted in writing within thirty (30) days after failure.

8.1.3.5 Written authorization to return merchandise under warranty must first be obtained from U.S.SAWS .

8.1.3.6 U.S.SAWS reserves the right to inspect and make the final decision on any merchandise returned under warranty.

8.1.3.7 U.S.SAWS offers no warranty with respect to accessories, including but not limited to, engines, motors, batteries, electrical boards, tires and any other parts not manufactured by us but which the original manufacturer warrants.

8.1.3.8 U.S.SAWS reserves the right to make product changes or improvements without prior notice and without imposing any obligation upon itself to install the same on its products previously sold.

8.1.3.9 The above warranty conditions can only be altered by U.S.SAWS. U.S.SAWS must confirm alterations in writing for each specific transaction.

8.1.3.10 U.S.SAWS reserves the right to establish specific warranty terms for used or demo machines on an individual transaction basis. Invoices covering such merchandise will clearly state the provisions of the applicable warranty for each specific transaction.

8.1.3.11 WE DO NOT AUTHORIZE ANY PERSON, REPRESENTATIVE OR SERVICE OR SALES ORGANIZATION TO MAKE ANY OTHER WARRANTY OR TO ASSUME FOR US ANY LIABILITY IN CONNECTION WITH THE SALE OF OUR PRODUCTS OTHER THAN THOSE CONTAINED HEREIN.

8.1.3.12 UNDER NO CIRCUMSTANCES SHALL US SAWS BE LIABLE TO CUSTOMER OR ANY OTHER PERSON FOR ANY DIRECT, INCIDENTAL, OR CONSEQUENTIAL DAMAGES RESULTING FROM THE USE OF THE PRODUCT OR ARISING OUT OF ANY BREACH OF ANY WARRANTY OR FOR ANY SPECIAL OR CONSEQUENTIAL DAMAGES OF ANY CHARACTER, INCLUDING WITHOUT LIMITATIONS, DAMAGES FOR ANY LOSS OF GOODWILL, WORK STOPPAGE, OR ANY AND ALL OTHER COMMERCIAL DAMAGES OR LOSSES.

8.1.3.13 U.S.SAWS MAKES NO OTHER WARRANTIES, EXPRESSED OR IMPLIED, INCLUDING, BUT NOT LIMITED TO, THE IMPLIED WARRANTIES OF MERCHANTABILITY AND FITNESS FOR A PARTICULAR PURPOSE WITH RESPECT TO THE US SAWS PRODUCTS SOLD PURSUANT THERETO.



MACHINE WARRANTY INFORMATION CARD

TO ENSURE THE PROPER WARRANTY COVERAGE IS EXTENDED TO THE OWNER OF THIS MACHINE, FILL OUT THE ATTACHED CARD COMPLETELY AND ACCURATELY.

WARRANTY REGISTRATION CARD

IMPORTANT! To ensure that your U.S.SAWS machine is covered under warranty, please fill in the following information and mail or fax it to U.S.SAWS, 8004B E. Broadway Ave. Tampa, FL 33619 Fax No. (813) 621-7125.

COMPANY
NAME
ADDRESS
INTENDED USE
DATE OF PURCHASE
INTENDED USE
SERIAL NUMBER

If you are not the owner of record as shown on the manual copy of the warranty registration card, do not operate this machine before contacting U.S.SAWS at 1-877-817-6687. Verify the following before operating the equipment:

CHANGE OF OWNER OR NEW ADDRESS REGISTRATION CARD

IMPORTANT! To ensure that your U.S.SAWS machine is covered under warranty, please fill in the following information and mail or fax it to U.S. SAWS, 8004B E. Broadway Ave. Tampa, FL 33619, Fax No. (813) 621-7125.

COMPANY
NAME
ADDRESS
INTENDED USE
DATE OF PURCHASE
INTENDED USE
SERIAL NUMBER

18

