



U.S.SAWS™



U.S.SAWS TRADITIONAL CORE DRILL WITH STAND

	<p>⚠ WARNING</p> <p>Read and fully understand operator's manual before using this machine.</p> <p>Failure to follow operating instructions could result in death or serious injury.</p>	
---	--	---

Notice of Copyright Protection

Copyright 2020, by U.S.SAWS . All rights reserved. This work may not be reproduced or disseminated in whole or in part by any means without the prior written permission of U.S.SAWS

2-09-2022

U.S.SAWS™

**WATERWORKS
DIVISION**

P: 866-987-7297 F: 813-621-7125
Visit us at www.ussaws.com
sales@ussaws.com



CONTENTS

1. Introduction
2. Symbols & Decals
3. Symbols & Decals
4. Safety Instructions
5. Safety Instructions
6. Safety Instructions
7. Safety Instructions
8. Operations
9. Operations
10. Operations
11. Parts
12. Parts
13. Parts
14. Maintenance
15. Warranty

INTRODUCTION

Introduction

The owner's manual is intended to point out some of the basic safety situations that maybe encountered during the normal operation & maintenance of the Traditional Core Drill Machine & to instruct you in safety practices for dealing with these conditions. Keep all manuals provided with your machine in a safe place at all times.

The information and specifications included in this publication were in effect at the time of approval for printing. U.S.SAWS reserves the right, however, to discontinue or change specifications or design at any time without notice and without incurring any obligation.

The traditional core drill is a fast, accurate and efficient way to drill holes in concrete and other materials. The core drill cores holes up to 12" in diameter. The drill is ideal for coring a range of materials including concrete, brick, and stone.

Disclosure

By purchasing and using the Traditional Core Drill you agree to release U.S.SAWS of any and all liability. Under no circumstances will U.S.SAWS be held liable for incidental or consequential damages resulting from the use of this product and/or defective parts or products associated with this product.

- It is the responsibility of the owner/user to ensure that the operating instructions have been read and understood by the operator before the operation of the equipment begins.
- It is the responsibility of the owner/user to understand and perform the maintenance and storage procedures as explained in the operating instructions.

Specifications

Model	Traditional Core Drill
Capacity	up to 12"
Electrical Requirements	110V
Cord Length	12'
RPM	410/ 620/ 830
Package Size	27"x7"x14"
Weight	94 lbs

This tool creates an enormous amount of force.
Beware of crushing your fingers or other body parts.



SYMBOLS & DECALS

For Safe Operation

You must be qualified for safe operation of the U.S.SAWS Traditional Core Drill machine. You must clearly understand the written instructions supplied by U.S.SAWS, be trained - including actual operation - & know the safety rules & regulations for the job site. It is a safety practice to point out & explain safety signs & practices to others & to make sure they understand the importance of following these instructions.

Be Safe

Human error is the result of many factors: carelessness, fatigue, sensory overload, preoccupation, unfamiliarity with the machine or attachments, or drugs or alcohol, to name a few. You can avoid serious injury or death caused by these & other unsafe work practices. Be safe and never assume accidents cannot happen to you.

For your safety and the safety of others, act safely and encourage your fellow workers to act safely as well.



Read and understand operator's manual before using this machine.

Failure to follow operating Instructions could result in injury or damage to equipment.

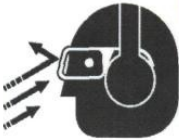

Always wear protective glasses or full face protection



Wear Head Protection, breathing protection, and the use of hearing protection is mandatory



Wear safety boots when operating this machine

SYMBOLS & DECALS

Dangers, Warnings and Cautions.

The purpose of safety symbols and explanations are to attract your attention to possible hazards and how to avoid them. The safety symbols and explanations do not by themselves eliminate any danger. The instructions or warnings they give are not substitutes for proper accident prevention measures.



DANGER: Indicates an imminently hazardous situation that if not avoided, will result in death or serious injury. This signal word is limited to the most extreme situations.



WARNING: Indicates a potentially hazardous situation that, if not avoided, could result in death or serious injury.



CAUTION: Indicates a potentially hazardous situation that, if not avoided may result in minor or moderate injury. It may also be used to alert against unsafe practices that may cause property damage.



Wear appropriate clothing



Wear hand protection



Wear proper electrostatic grounding equipment at all times.



Wear proper electrostatic grounding equipment at all times.

SAFETY INSTRUCTIONS

KNOW THE RULES & YOUR EQUIPMENT.

Most job sites have rules governing equipment use & maintenance. Before starting at a new work location, check with the supervisor or safety coordinator. Ask about any rules or regulations you need to abide.

OSHA enforces federal laws within the United States that apply to the safe operation, application, & maintenance of equipment on job sites. It is the employer's responsibility to comply with these laws.

Do not operate this machine unless you have read the operations and maintenance manual carefully.

RECEIVE PROPER TRAINING.

Do not operate this machine unless you have received operational and maintenance training from a U.S.SAWS representative or from an authorized distributor for U.S.SAWS.

PROTECT YOUR FEET.

Observe all applicable local, state and federal safety regulations. Wear OSHA approved foot protection.

PROTECT YOUR EYES.

Observe all applicable local, state and federal safety regulations. Wear OSHA approved safety glasses.

PROTECT YOUR HEARING.

Observe all applicable local, state and federal safety regulations. Wear OSHA approved hearing protection.

DRESS PROPERLY.

Do not wear loose clothing or jewelry that can be caught in moving parts. Wear protective hair covering to contain long hair. Keep hair away from motor air vent. Rubber gloves and non-skid footwear are recommended when working outdoors.

AVOID A DANGEROUS ENVIRONMENT.

Do not expose machine to rain. Do not use machine in wet conditions. Water entering a power tool will increase the risk of electric shock. Keep work area well lit. When working at an elevated location, pay attention to articles and persons below. If operating the power tool in damp locations is unavoidable, use a Ground Fault Circuit Interrupter (GFCI) protected supply. Use of an GFCI reduce the risk of electric shock.

AVOID ANY AREAS OR ACTIONS THAT EXPOSE YOU TO CARBON MONOXIDE.

Exhaust gas from gasoline engines contains dangerous carbon monoxide. Breathing it can cause unconsciousness and even kill you. Always operate gasoline engine machines in a well-ventilated area. Do not operate in areas where exhaust fumes could accumulate without wearing appropriate respiratory protection. Consult your employer and OSHA regarding use of appropriate respirator for dangerous carbon monoxide gases.

KEEP WORK AREA CLEAN. DO NOT RUN OVER ANYTHING.

Loose objects could be thrown from crack. Make sure area to be cut is clear from people and any loose objects, nuts, bolts, etc. Never run over any loose objects.

SAFETY INSTRUCTIONS

KEEP CHILDREN AND VISITORS AWAY.

Do not allow anyone to stand in line with the blade path. Do not let children or visitors contact machine or extension cord. Keep children and visitors away from the work area.

KEEP FIRM GRIP ON MACHINE.

During normal operation as instructed in Section 6.0, keep a firm hold on the handle grips and maintain control of the machine until the blade completely stops.

SHUT OFF MACHINE.

When not in use, before servicing and when changing accessories shut off engine. Release the lever switch and move the on/off switch to the OFF position. Move the fuel valve lever to the OFF position.

STORE IDLE EQUIPMENT.

The machine and tools should be stored in a dry and secure location when not in use. Keep equipment out of reach of children.

DO NOT OVERREACH.

Keep proper footing and balance at all times.

OBTAIN SAFETY DATA SHEET (SDS) FOR ALL WORK SURFACE MATERIALS.

This includes primers, all coatings, adhesives, tile and crack filling materials, etc. Do not attempt to cut, clean out or remove material without SDS information. Consult SDS sheet for hazards information. Be aware that some materials are explosive as a dust.

MAINTAIN MACHINE WITH CARE.

Keep machine clean and follow maintenance procedures for better and safer performance. Keep handles dry, clean, and free from oil and grease. Follow instructions for lubricating and changing accessories.

REMOVE ADJUSTING TOOLS.

Form a habit of checking to see that tools such as adjusting wrenches are removed from the machine and properly stored before starting the engine.

STAY ALERT.

Watch what you are doing. Use common sense. Do not operate machine when you are tired or fatigued.

DO NOT USE DRUGS, ALCOHOL, MEDICATION.

Do not operate machine while under the influence of drugs, alcohol, or any medication.

KEEP THE RIGHT PARTS IN THE RIGHT POSITIONS.

Do not operate machine with parts missing or improperly mounted.

CHECK DAMAGED PARTS.

Verify all machine guards are in good condition and will function properly before using the machine. Check for alignment of moving parts, binding of moving parts, breakage of parts, mounting, and any other conditions that may affect machine operation. A guard, power switch or other part that is damaged should be properly repaired or replaced by an authorized service center unless indicated elsewhere in this instruction manual. Do not operate machine if lever or engine on/off switch does not function properly.

SAFETY INSTRUCTIONS

SECURELY MOUNT ACCESSORIES TO THE MACHINE.

Extra care must be taken an elevated location to prevent injury to someone on a lower level in the event the tool or accessory should drop. Do not operate without fall protection for operator and debris protection for public.

NEVER TOUCH THE MOVING PARTS.

Never touch moving parts such as shaft and drill extensions.

STOP OPERATION IMMEDIATELY IF ANY ABNORMALITY IS DETECTED.

Stop using machine immediately if any abnormalities are observed during operation. Examples of abnormalities include unusual noise and vibration.

WHEN REPLACING A PART, USE THE SAME TYPE AND QUALITY.

When replacing a component part with a new one, use only the same type and quality of new part. Never attempt to repair a machine if you are unfamiliar with proper procedures and techniques required.

LOAD AND UNLOAD SAFELY.

Use proper heavy lifting procedures. Read & understand manuals before loading & unloading.

SAVE THESE INSTRUCTIONS.

Refer to this operations and maintenance manual as well as any additional instructions included from other manufacturers and organizations.

This tool creates an enormous amount of force.
Beware of crushing your fingers or other body parts.



SAFETY INSTRUCTIONS



DUST WARNING

Cutting, especially when DRY cutting, generates dust that comes from the material being cut, which frequently contains silica.

Silica is a basic component of sand, quartz, brick clay, granite and numerous other minerals and rocks. Exposure to excessive amount of such dust can cause:

- Respiratory diseases (affecting your ability to breath), including chronic bronchitis, silicosis and pulmonary fibrosis from exposure to silica. These diseases may be fatal;
- Skin irritation and rash; and
- Cancer according to NTP* and IARC*

* National Toxicology Program, International Agency for Research on Cancer

Take precautionary steps

- Avoid inhalation of and skin contact with dust, mist and fumes;
- Wet cut when feasible, to minimize dust;
- Wear and ensure that all bystanders wear appropriate respiratory protection such as dust masks designed to filter out microscopic particles. (See OSHA 29 CFR Part 1910.1200)

California Prop 65 Warning: Use of this product can cause exposure to materials known to the State of California to cause cancer and/or birth defects or other reproductive harm.

	<p> WARNING</p> <p>Read and fully understand operator's manual before using this machine.</p> <p>Failure to follow operating instructions could result in death or serious injury.</p>	
--	--	--

OPERATION

Friction Clutch

Clutch provides protection under high-load mechanical condition for operator, machine and bit. Do not exceed 3-4 second of clutch engagement, as it will cause excessive wear on the clutch plates.

Master Switch and Overload Protective Device

After pressing on switch, machine should start smoothly, If load is not reduced after several seconds, switch will shut off automatically. Start again if remove load, machine will again start smoothly.

To improve the efficiency of drilling, some machines have 3 speed gear box. Select a gear that is appropriate for the load, material and bit size.

Extension Cords

Do not use the tool if the cord or plug is damages. IF damaged, have it repaired by an authorized service facility before use. If the plug will not fir the outlet, have a proper outlet installed by a qualified electrician. The use of a circuit protected by a ground fault interrupter (GFCI) is highly recommended.

Use extension cords of the proper cable size, referring to the following chart.

MOTOR SPECS			EXTENSION CORD LENGTH			
Motor	Voltage	Amps	25'	50'	100'	200'
154633	120V 1 Ph	20	12 ga	10 ga	6 ga	4 ga
159264	120V 1 Ph	15	14 ga	10 ga	8 ga	4 ga

WARNING

Never use a extension cord smaller than shown in the chart. Be sure your extension cord is properly wired and in good electrical condition. Always replace a damaged extension cord or have it repaired by a qualified electrician before using it. Protect your extension cords from sharp objects, excessive heat and damp or wet areas.

NOTICE: Using an extension cord with inadequately sized wire causes drop in voltage, resulting in loss of power and possible tool damage.

SECURING THE RIG: RECOMMENDED METHODS

A. USE A CONCRETE ANCHOR. Use either a 1/2 or 5/8 concrete anchor to secure the base to the work surface. Always be sure to level the rig and tighten the lock nuts on the leveling screws before tightening the anchor. Manta base should be secured using a concrete anchor. Insert bolt through the washer plate then into slot located on the base and then tighten the bolt firmly in the anchor. Follow concrete anchor manufactures instructions.

WARNING

It is essential to always secure the rig to the work surface to help prevent personal injury and also to protect the rig. An unsecured rig could rotate during drilling and possibly cause injury. It could also cause the bit to chatter against the work surface or bind in a hole, which can fracture the diamond. Always test the anchor for firm attachment before drilling.

OPERATION

DRILLING SPEEDS

Specifications for the different motors are listed in the table below.

NOTICE: Change the gears only when the motor is off.

All building materials and work surfaces are composed of aggregates of various size. Aggregates are materials such as gravel or crushed stone. The size of the grains and the hardness of the material affects the speed of drilling. Most building materials contain some type of steel reinforcements. All

Traditional bits are designed to cut through these types of reinforcing steel. However, bits should never be used for drilling solid steel plates. Proper selection of the diamond core bit should be based on material to be drilled and performance requirements.

WATER SUPPLY

An adequate supply of clean water is necessary for drilling. Connect the water supply hose to the hose fitting on the output of the core drill motor. Take precautions that the water supply will not be interrupted during the drilling operations.

NOTICE: If a bit is run dry it can be ruined in a few seconds.

- Thread anti-clockwise to attach core bit.
- Thread clockwise to loosen.



To reduce the risk of injury, always unplug tool before attaching or removing accessories. Only use specifically recommended accessories. Others may be hazardous.



Diamond tools improperly used are dangerous. Comply with American National Standards Institute Safety Code, B7.1 and, Occupational Safety and Health Act covering Speed, Safety Guards, Flanges, Mounting Procedures, General Operating Rules, Handling, Storage and General Machine Conditions.

DRILLING PROCEDURE

When drilling through concrete floors, the core will generally drop from the diamond bit. Caution should be provided for people and property below the drilling area.

1. Ensure that you have read and fully understand the complete operation of the Traditional Core Drill you have purchased prior to commencing drilling operations.
2. Select and install a diamond core bit appropriate for the job.

NOTE: Grease the bit threads to help prevent the bit from seizing on the spindle due to surface corrosion.

3. Select either high or low gear speed according to the chart in the Drilling Speeds section of this manual. (Do not shift speed when motor is on.)
4. Connect water hose to water swivel.
5. Secure the rig as described in the Securing the Rig section of this manual.

OPERATION

DEEP DRILLING

When drilling holes that are longer than the core bit, follow the steps below.

1. Begin drilling the hole as usual. When you have drilled to the length of the bit, retract the bit from the hole and turn off the motor and water as usual.
2. Break off the core by driving a chisel or slender wedge into the circular kerf. Remove the core using core tongs, bent music wire or anchor bolts.
3. After removing the core, insert the bit carefully into the hole, attach a bit extension to the bit and core drill rig, then continue drilling as usual.

MAINTENANCE

Periodic maintenance, including cleaning, lubrication and inspection for wear and damage are routine servicing procedures. Following the procedures as outlined can prevent serious damage or malfunctioning of the machine, and aid in preserving the useful life of core drill bits.



Before performing any maintenance to the Traditional Core Drill always unplug the unit from the electrical power source. Ensure the On-Off switch is in the Off position, after servicing, and before plugging the unit back in.

CLEANING

Clean the machine after use, being careful to remove dust and slurry from the motor, vents, carriage and column. Keep tool handles clean, dry and free of oil and grease. Use only mild soap and a damp cloth to clean this tool since certain agents and solvents are harmful to plastics and other insulated parts.



Never use flammable or combustible solvents around tools.

PARTS

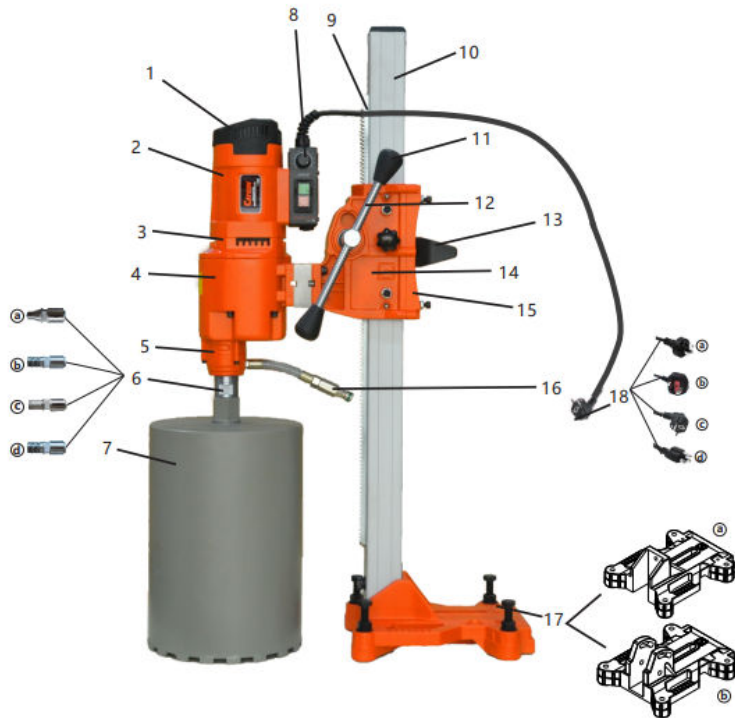

1. Cover

2. Stator shell

3. Cover

4. Gearbox

5. Water seal

6. Spindle (a: Beijing thread; b, 1-1/4" -3UNC; C: 1-1/4" -7UNC, d: 1-1/4" -7UNC G/1/2)

7. Core bit

8. Motor switch

9. Rack

10. Column

11. Handle

12. Rocking bar

13. Fitting

14. Lifter

15. Lifting cover

16. Hose tap

17. Base (a. normal stand b. angle adjustable bracket)

18. Plug (A. CN B. GB C. EP D. US)

PARTS

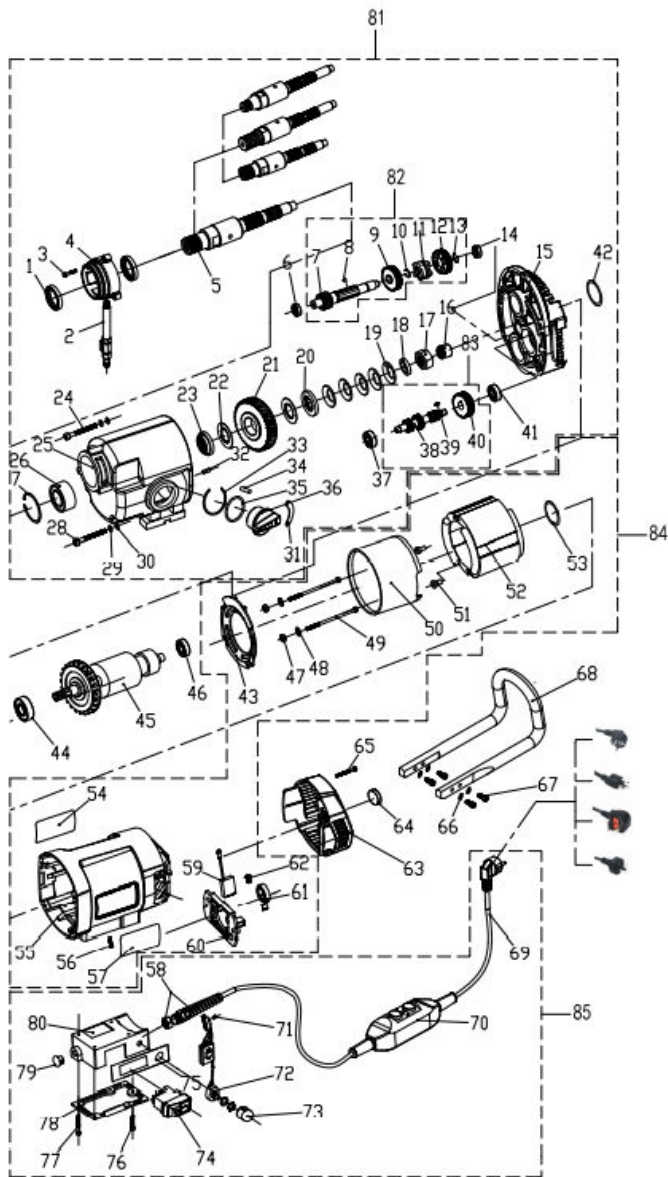

PARTS

NO.	Parts name	QTY	NO.	Parts name	QTY
1	Water seal 40 * 50 * 7	2	54	Business Sign 200C	1
2	Hose faucet 200A-EU	1	55	Stator hull 200C	1
3	Hegonal screw M5 * 18	3	56	Cross level screw M4 * 8 white	1
4	Watershed 250C	1	57	Parameter card OND(58.5 * 36.5)	1
5	Main axis 230 tune	1	58	Fold proof connector M16 * 1.5	1
6	Bearing 6202	1	59	Carbon Brush 200A	2
7	Class II tooth axis 250A/3 -6(12)	1	60	Brush frame 200C	1
8	Ball head plunger M8 * 15	1	61	Bypass 200A	2
9	Type II High Speed Gear 250A/3 -5	1	62	Round Head Cross Screw M4 * 8(Copper)	2
10	Stop Ring 18	1	63	Cover 200C	1
11	Class II sliding gear 250A/3 -4	1	64	Horizontal instrument ϕ 15 * 8	1
12	Type II low-speed gear 250A/3 -3	1	65	Hegonal screw M4 * 10	2
13	Card 16	1	66	Pad M5	4
14	Bearing 6201	1	67	Hegonal screw M5 * 10	4
15	Middle cover 250C	1	68	Curved handle 200D	1
16	Roller bearings BAM1212	1	69	Power cord 3 * 1.5 * 3.5 M	1
17	Nut 200A	1	70	Leakage protector PD16	1
18	Ring 250	1	71	Round Cross Screw M4 * 10	1
19	Curved bullet pad 200A	5	72	Governor SCY20504050(A)	1
20	Flesh iron 200A	2	73	Speed control knob KN-8D	1
21	Host gear 250A-5(12)	1	74	Electromagnetic switch KJD17	1
22	Separation film 200A	2	75	Speed adjustment label SCY	1
23	Hand-key pad 250A	1	76	Hegonal screw M4 * 25	1
24	Hegonal screw M6 * 125(half tooth)	2	77	Hegonal screw M4 * 50(half tooth)	4
25	Gear box 250C	1	78	Switching box cover 200A-T-FS	1
26	Bearing 3205	1	79	Button head SKT-10	1
27	Inner card 52	1	80	Switch Box 200A-T-FS	1
28	Hegonal screw M6 * 135(half tooth)	2			
29	Pad M6	4			
30	Pad M6	4			
31	File plate 300A/3	1			
32	Cylinder pin 4 * 12	1			
33	Stop ring ϕ 40	1			
34	Cylinder pin 5 * 28	1			
35	O-ring ϕ 42 * 3.1	1			
36	Dialing knob 250C	1			
37	Bearing 6201	1			
38	Class I tooth axis 250A/3 -2	1			
39	Marketing 4 * 10	1			
40	Class I gear 250C-1(B)	1			
41	Bearing 6201	1			
42	O-ring ϕ 34.5 * 2.65	1			
43	Breeze 200C	1			
44	Bearing 6202	1			
45	Rotor OND-935 / 3E	1			
46	Bearing 6201	1			
47	Loose nut M5	2			
48	Pad M5	2			
49	Hegonal screw M5 * 105(half tooth)	2			
50	Interior 200C	1			
51	Insulation sleeve 200A	2			
52	Stator OND-935 / 3E	1			
53	O-ring ϕ 38 * 3.1	1			

MAINTENANCE

Clean the machine with a dry or moist rag and not with a jet of water. Make sure that no water gets into the motor or the switch box. Ensure that the ventilation slots are always clean. Clean and greases the tool thread regularly.

Oil bath gear

The gear oil should be changed after 300 hours of operation. Ensure that this work is carried out in a specialist workshop, or proceed as follow: Clamp the machine vertically in the vice. Remove the three hexagon socket screws. Take off motor and intermediate cover. Change gear oil use only original oil. The filling quantity is 300-310ml. To reverse disassembly procedures

ATTENTION: if gear oil escapes, stop the machine immediately. Leakage of oil damages the gear.

Water connection

If water escapes from the overflow hole on the water connection ring, the rotary shaft seals must be replaced immediately. This should only be done in an authorized specialist workshop.

Carbon brushes

The carbon brushes should be examined for wear after about 300 hours in operation, and replaced if necessary. As with all other work on the motor, this should only be carried out by an electrician.

WARRANTY

Warranty

This document is to be used as a guide in determining warranty policies and procedures for U.S.SAWS and its U.S.SAWS products. It is to be used in determining whether a warranty is justified and as a procedural guide in completing a U.S.SAWS warranty claim form.

Warranty Responsibility

The distributor or the end user must prepare a Machine Warranty Information Card when the machine is delivered. Failure to comply will make any and all warranties on this equipment null and void. Credit for warranty repairs will be given only after receipt of the WARRANTY CLAIM FORM, properly completed with all the required details. Submittal details are described later in this document.

Warranty Policy

U.S.SAWS warrants its U.S.SAWS products against defects in material and workmanship under normal and proper use for a period of one year (365) days from the date of delivery; in the case of Rental Fleet Machines, date of assignment to Rental Fleet. Such warranty is extended only to the buyer who purchases the equipment directly from U.S.SAWS or its authorized distributor. This warranty does not include expendable parts such as, but not limited to, plugs, cutters, blades, blast wheel, wear parts, liners and seals.

The obligation under this warranty is strictly limited to the replacement or repair, at US SAWS's option, of machines and does not include the cost of transportation, loss of operating time, or normal maintenance services.

This warranty does not apply to failure occurring as a result of abuse, misuse, negligence, corrosion, erosion, normal wear and tear, alterations or modifications made to the machine without express written consent of U.S.SAWS .

Warranty request must be submitted in writing within thirty (30) days after failure.

Written authorization to return merchandise under warranty must first be obtained from U.S.SAWS .

U.S.SAWS reserves the right to inspect and make the final decision on any merchandise returned under warranty.

U.S.SAWS offers no warranty with respect to accessories, including but not limited to, engines, motors, batteries, electrical boards, tires and any other parts not manufactured by us but which the original manufacturer warrants.

U.S.SAWS reserves the right to make product changes or improvements without prior notice and without imposing any obligation upon itself to install the same on its products previously sold.

The above warranty conditions can only be altered by US SAWS. US SAWS must confirm alterations in writing for each specific transaction.

U.S.SAWS reserves the right to establish specific warranty terms for used or demo machines on an individual transaction basis. Invoices covering such merchandise will clearly state the provisions of the applicable warranty for each specific transaction.

WE DO NOT AUTHORIZE ANY PERSON, REPRESENTATIVE OR SERVICE OR SALES ORGANIZATION TO MAKE ANY OTHER WARRANTY OR TO ASSUME FOR US ANY LIABILITY IN CONNECTION WITH THE SALE OF OUR PRODUCTS OTHER THAN THOSE CONTAINED HEREIN.

UNDER NO CIRCUMSTANCES SHALL US SAWS BE LIABLE TO CUSTOMER OR ANY OTHER PERSON FOR ANY DIRECT, INCIDENTAL, OR CONSEQUENTIAL DAMAGES RESULTING FROM THE USE OF THE PRODUCT OR ARISING OUT OF ANY BREACH OF ANY WARRANTY OR FOR ANY SPECIAL OR CONSEQUENTIAL DAMAGES OF ANY CHARACTER, INCLUDING WITHOUT LIMITATIONS, DAMAGES FOR ANY LOSS OF GOODWILL, WORK STOPPAGE, OR ANY AND ALL OTHER COMMERCIAL DAMAGES OR LOSSES.

U.S.SAWS MAKES NO OTHER WARRANTIES, EXPRESSED OR IMPLIED, INCLUDING, BUT NOT LIMITED TO, THE IMPLIED WARRANTIES OF MERCHANTABILITY AND FITNESS FOR A PARTICULAR PURPOSE WITH RESPECT TO THE US SAWS PRODUCTS SOLD PURSUANT THERETO.